

# PSA Oxygen Generator

# Reliant



The Reliant is an oxygen generator ideal for use in many applications. The Reliant's ability to deliver up to 95% oxygen concentration at flows of up to 17 SCFH (0.44 Nm<sup>3</sup>/hr or 8 LPM) make it a great fit for medical clinics requiring up to 50 psig (345 kPa or 3.45 barg).

## Typical Applications

- Medical Oxygen Supply
- Veterinary Medicine

*Note: The 220 V ~ ±10%, 50 Hz configuration is for medical use outside of the USA.*

## Features

- Self-contained (internal air compressor)
- Microprocessor controlled
- Low operating cost
- Automatic and unattended operation
- Transportable design
- Easy to install and maintain
- Oxygen concentration monitor and alarm
- Optional auxiliary oxygen receiver (free standing)

## Specifications

Product Flow <sup>1</sup>	17 SCFH (0.44 Nm <sup>3</sup> /hr or 8 LPM)
Product Pressure	50 psig (345 kPa or 3.45 barg)
Product Concentration	Up to 95%
Product Dew Point	-100°F (-73°C)
Dimensions (W x D x H) (Nominal)	22.5 x 24.5 x 36.25 in (57.2 x 62.3 x 92.1 cm)
Weight	175 lb (79 kg)
Physical Connections	
Product Gas Outlet	B size oxygen demand valve
Sound Level	58 dBA @ 1 meter, open field conditions
Ambient Operating Conditions	Locate the oxygen concentrator in a well-ventilated area that is protected from weather elements and remains between 40°F (4°C) and 112°F (44°C)
Control Power Requirements (Single Phase)	220 V ±10%, 50 Hz, 3.0 A
Typical Power Consumption	680 W
<b>60 Gallon Oxygen Receiver (Optional)</b>	
Dimensions (Dia. x H)	26 x 52 in (65 x 131 cm)
Weight	159 lb (72 kg)

<sup>1</sup> SCF (Standard cubic foot) gas measured at 1 atmosphere and 70°F / Nm<sup>3</sup> (Normal cubic meter) gas measured at 1 atmosphere and 0°C / LPM (Liters per minute) gas measured at 1 atmosphere and 21°C

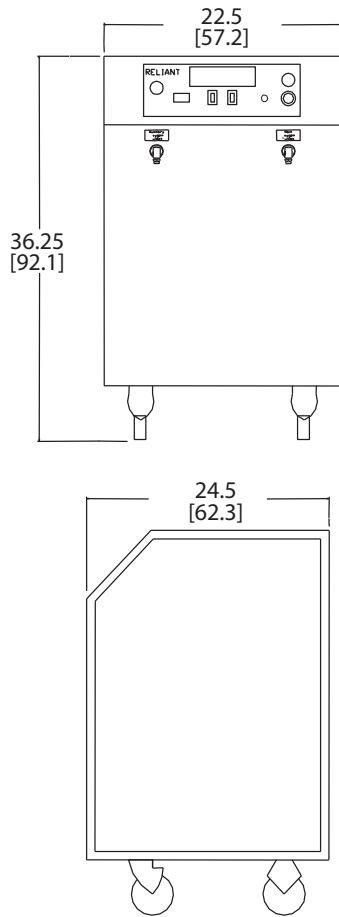

Note: All dimensions are nominal.

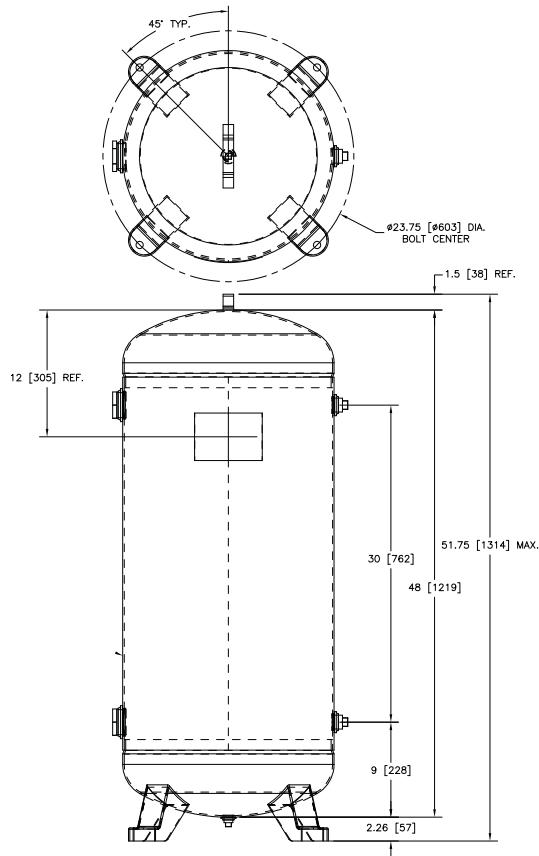

Optional 60 Gallon Receiver

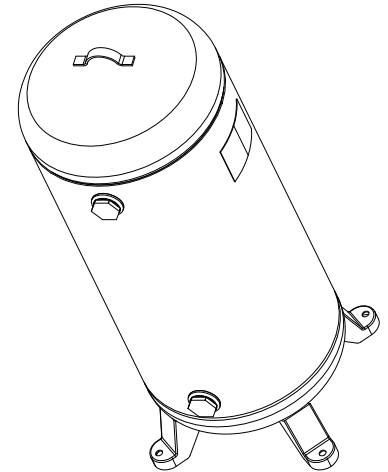

## Ordering Information

Model	Part Number	Description
Reliant (FOR EXPORT ONLY)	AS072-3	220 V ~ ±10%, 50 Hz with oxygen concentration monitor (LED indicator)
	AS072-5	220 V ~ ±10%, 50 Hz with oxygen concentration monitor (LED indicator), Russian Language
Required Accessory	KI046-1	Accessory Kit (10 ft Stainless Braided Oxygen Hose & Primary/Secondary Oxygen Ball Valve Assembly)
	KI048-1	Accessory Kit (10 ft Stainless Braided Oxygen Hose & Oxygen Receiver Purge Ball Valve)
	KI168-1	Accessory Starter Kit
Optional Accessories	TA150-1	60 Gallon Oxygen Receiver
	AN021-1	Oxygen Analyzer (Maxtec Handi)
	AN005-1	Oxygen Analyzer (Maxtec Max O <sub>2</sub> Plus)
	AN075-1	Oxygen Analyzer/Sensor (Maxtec Max O <sub>2</sub> Plus)

Shipping Information	Reliant	60 Gallon Oxygen Receiver
Class	92.5	70
Commodity Classification Number	8421.39.8040	7311.00.0000
Dimensions (W x D x H)	28 x 30 x 45 in (71 x 76 x 114 cm) with Accessory Kit	28 x 30 x 56 in (71 x 76 x 142 cm)
Gross Weight	233 lb (106 kg) with Accessory Kit	177 lb (80 kg)

### Warranty: 1 Year Parts and Factory Labor\*

\* An unprotected or inadequately ventilated environment, or improper control power may cause damage to the oxygen generator not covered under warranty.

All performance ratings based on an ambient temperature up to 100°F (38°C), up to 1,000 feet elevation, and 80% relative humidity.



© 2020 AirSep Corporation. All Rights Reserved.  
AirSep reserves the right to discontinue its products, or change the prices, materials, equipment, quality, descriptions, specifications and/or processes to its products at any time without prior notice and with no further obligation or consequence. Any rights expressly stated herein are reserved by us, as applicable.

**BROWARD & C**  
MEDICAL GAS SPECIALISTS

1533 SW 1st Way, Suite F19

Deerfield Beach, FL 33441

Office: 954-725-1470

Email: [orders@medicalgassupplier.com](mailto:orders@medicalgassupplier.com)