

# Emergency Oxygen Inlet Station Recessed Mount High Pressure



## General Specifications:

The "Emergency Gaseous Oxygen Inlet Station" shall be an Amico Alert-1 series.

As required by NFPA 99 and CSA Z7396.1, oxygen systems having the source of supply outside the building shall have an inlet to connect a temporary, auxiliary source of supply for emergency or maintenance situations. This connection shall include necessary valves and a high pressure regulator to allow for an emergency supply of oxygen and isolation of the normal source of supply. The inlet connection shall only accept a CGA 540 connection and be provided with a nut to prevent entry of foreign matter into the oxygen system when not in use.

A 1" brass ball valve and a high pressure regulator controls access to the emergency supply and indicates the supply pressure and the pressure being introduced into the oxygen pipeline. Maximum input pressure of 3,000 psi.

The Emergency Gaseous Oxygen Inlet shall be housed in a weather tight recessed enclosure.

The enclosure door shall be labelled "Emergency High Pressure Gaseous Oxygen Inlet" and shall be equipped with a staple for padlocking to allow entry only by authorized personnel. A mounting frame shall extend completely around the enclosure to trim recessed mounting on an exterior wall.

The interior of the enclosure shall be clearly labelled with instructions for connection and operation of the emergency oxygen inlet.

Bronze body check valves with female pipe threads on each end shall be provided for installation in the main and emergency supply pipeline in accordance with NFPA 99 and CSA Z7396.1.

A brass body relief valve with the relief pressure set @75 psi shall be provided for installation in the emergency supply line. The relief valve shall be supplied factory cleaned for oxygen service and shall automatically reset after discharging to provide a positive seal.

Amico products comply with NFPA 99 and CSA Z7396.1.

## Features:

- High pressure CGA 540 cylinder connection
- Lockable weather tight enclosure, for outside mounting
- Dual gauges for display of supply and delivery pressures
- Bronze body check valves and brass body relief valves available for installation (must be ordered separately)

## Project

---

---

---

# Technical Specifications

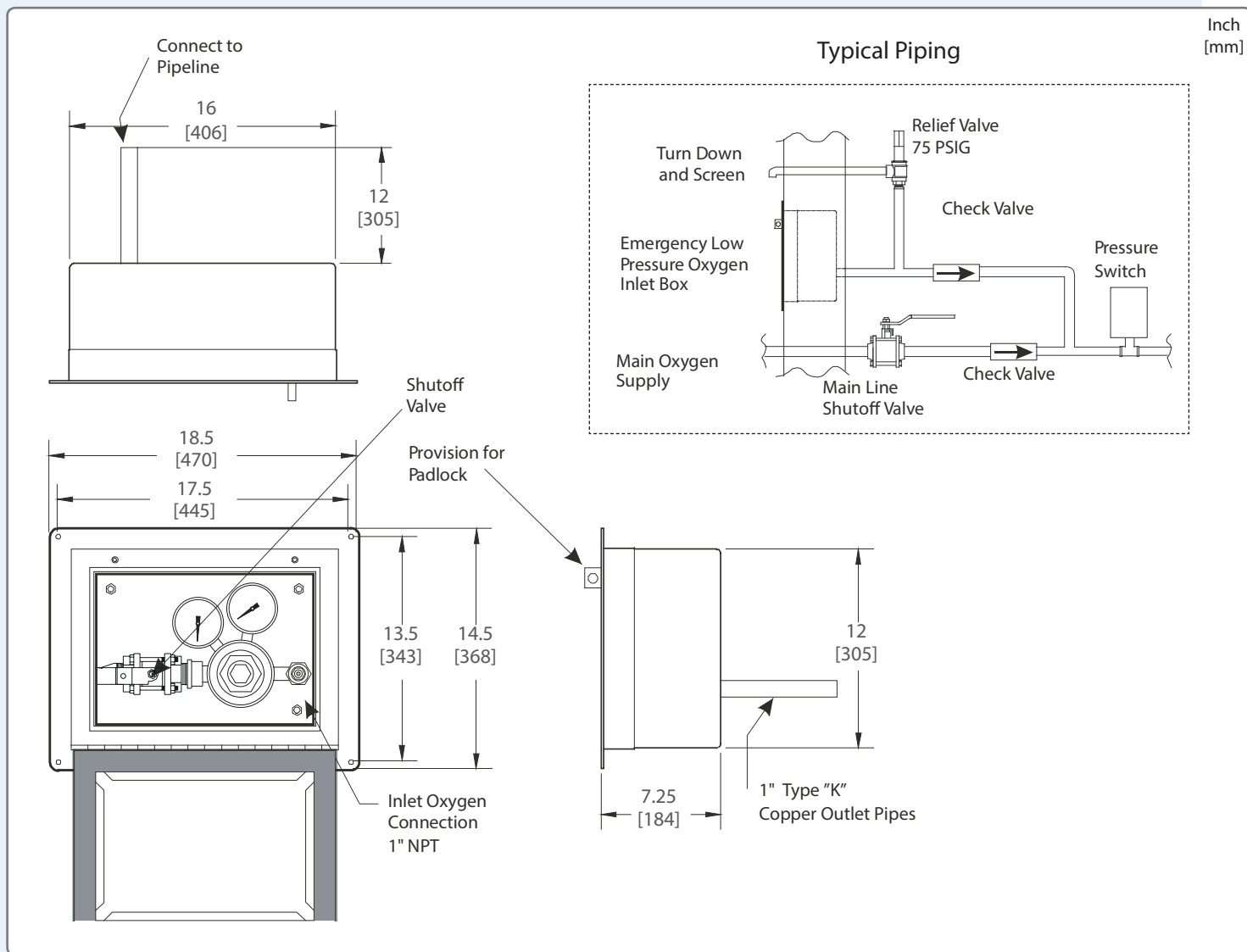

## Model Numbers

Emergency High Pressure Oxygen Inlet Station Recessed Wall Mounting:

**M-FILL-OXY-HP**

Optional Check and Relief Valves (to be ordered separately):

Check Valve 1"

**VV-CHK3-EXT10**

Check Valve 1-1/2"

**VV-CHK3-EXT15**

Check Valve 2"

**VV-CHK3-EXT20**

Relief Valve Pipe Away Adapter 1/2" NPT (NFPA)

**M-X-PIPEAWAY-05**

Relief Valve (NFPA)

**M-X-MAN-72W-075**

Relief Valve (CSA)

**M2-X-MAN-73-075**

Distributed By:

